

# **FUNAI** **SERVICE MANUAL**

## **Main Section**

- Specifications
- Adjustment Procedures
- Troubleshooting
- Schematic Diagrams
- CBA's
- Exploded Views
- Parts List

## **Plasma Display Module Section**

- Disassembly Procedures
- Troubleshooting
- Exploded Views
- Parts List

## **PLASMA DISPLAY**

### **F42PDME**

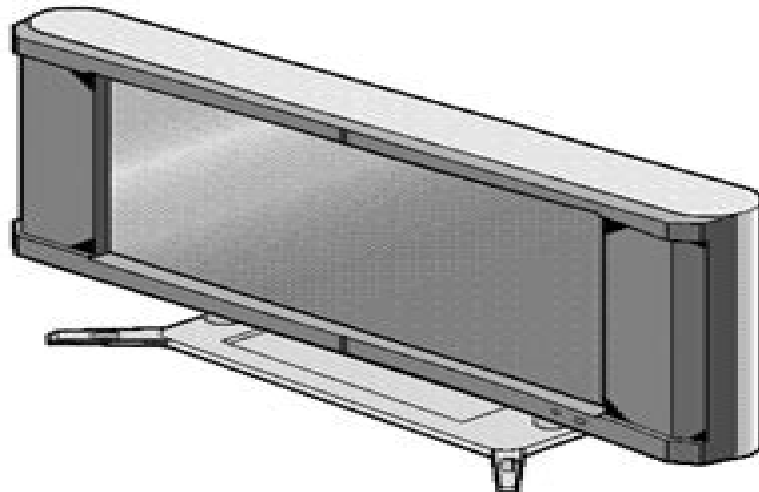

# Funai F42pdme Manual

**SA Adler**



## **Funai F42pdme Manual:**

Ignite the flame of optimism with Crafted by is motivational masterpiece, Fuel Your Spirit with **Funai F42pdme Manual** . In a downloadable PDF format ( \*), this ebook is a beacon of encouragement. Download now and let the words propel you towards a brighter, more motivated tomorrow.

<https://www.portal.goodeyes.com/data/virtual-library/fetch.php/fenwalnet%202015%20manual.pdf>

## **Table of Contents Funai F42pdme Manual**

1. Understanding the eBook Funai F42pdme Manual
  - The Rise of Digital Reading Funai F42pdme Manual
  - Advantages of eBooks Over Traditional Books
2. Identifying Funai F42pdme Manual
  - Exploring Different Genres
  - Considering Fiction vs. Non-Fiction
  - Determining Your Reading Goals
3. Choosing the Right eBook Platform
  - Popular eBook Platforms
  - Features to Look for in an Funai F42pdme Manual
  - User-Friendly Interface
4. Exploring eBook Recommendations from Funai F42pdme Manual
  - Personalized Recommendations
  - Funai F42pdme Manual User Reviews and Ratings
  - Funai F42pdme Manual and Bestseller Lists
5. Accessing Funai F42pdme Manual Free and Paid eBooks
  - Funai F42pdme Manual Public Domain eBooks
  - Funai F42pdme Manual eBook Subscription Services
  - Funai F42pdme Manual Budget-Friendly Options
6. Navigating Funai F42pdme Manual eBook Formats

- ePub, PDF, MOBI, and More
  - Funai F42pdme Manual Compatibility with Devices
  - Funai F42pdme Manual Enhanced eBook Features
7. Enhancing Your Reading Experience
    - Adjustable Fonts and Text Sizes of Funai F42pdme Manual
    - Highlighting and Note-Taking Funai F42pdme Manual
    - Interactive Elements Funai F42pdme Manual
  8. Staying Engaged with Funai F42pdme Manual
    - Joining Online Reading Communities
    - Participating in Virtual Book Clubs
    - Following Authors and Publishers Funai F42pdme Manual
  9. Balancing eBooks and Physical Books Funai F42pdme Manual
    - Benefits of a Digital Library
    - Creating a Diverse Reading Collection Funai F42pdme Manual
  10. Overcoming Reading Challenges
    - Dealing with Digital Eye Strain
    - Minimizing Distractions
    - Managing Screen Time
  11. Cultivating a Reading Routine Funai F42pdme Manual
    - Setting Reading Goals Funai F42pdme Manual
    - Carving Out Dedicated Reading Time
  12. Sourcing Reliable Information of Funai F42pdme Manual
    - Fact-Checking eBook Content of Funai F42pdme Manual
    - Distinguishing Credible Sources
  13. Promoting Lifelong Learning
    - Utilizing eBooks for Skill Development
    - Exploring Educational eBooks
  14. Embracing eBook Trends
    - Integration of Multimedia Elements
    - Interactive and Gamified eBooks

## Funai F42pdme Manual Introduction

Funai F42pdme Manual Offers over 60,000 free eBooks, including many classics that are in the public domain. Open Library: Provides access to over 1 million free eBooks, including classic literature and contemporary works. Funai F42pdme Manual Offers a vast collection of books, some of which are available for free as PDF downloads, particularly older books in the public domain. Funai F42pdme Manual : This website hosts a vast collection of scientific articles, books, and textbooks. While it operates in a legal gray area due to copyright issues, its a popular resource for finding various publications. Internet Archive for Funai F42pdme Manual : Has an extensive collection of digital content, including books, articles, videos, and more. It has a massive library of free downloadable books. Free-eBooks Funai F42pdme Manual Offers a diverse range of free eBooks across various genres. Funai F42pdme Manual Focuses mainly on educational books, textbooks, and business books. It offers free PDF downloads for educational purposes. Funai F42pdme Manual Provides a large selection of free eBooks in different genres, which are available for download in various formats, including PDF. Finding specific Funai F42pdme Manual, especially related to Funai F42pdme Manual, might be challenging as theyre often artistic creations rather than practical blueprints. However, you can explore the following steps to search for or create your own Online Searches: Look for websites, forums, or blogs dedicated to Funai F42pdme Manual, Sometimes enthusiasts share their designs or concepts in PDF format. Books and Magazines Some Funai F42pdme Manual books or magazines might include. Look for these in online stores or libraries. Remember that while Funai F42pdme Manual, sharing copyrighted material without permission is not legal. Always ensure youre either creating your own or obtaining them from legitimate sources that allow sharing and downloading. Library Check if your local library offers eBook lending services. Many libraries have digital catalogs where you can borrow Funai F42pdme Manual eBooks for free, including popular titles. Online Retailers: Websites like Amazon, Google Books, or Apple Books often sell eBooks. Sometimes, authors or publishers offer promotions or free periods for certain books. Authors Website Occasionally, authors provide excerpts or short stories for free on their websites. While this might not be the Funai F42pdme Manual full book , it can give you a taste of the authors writing style. Subscription Services Platforms like Kindle Unlimited or Scribd offer subscription-based access to a wide range of Funai F42pdme Manual eBooks, including some popular titles.

## FAQs About Funai F42pdme Manual Books

**What is a Funai F42pdme Manual PDF?** A PDF (Portable Document Format) is a file format developed by Adobe that preserves the layout and formatting of a document, regardless of the software, hardware, or operating system used to view or print it. **How do I create a Funai F42pdme Manual PDF?** There are several ways to create a PDF: Use software like

Adobe Acrobat, Microsoft Word, or Google Docs, which often have built-in PDF creation tools. Print to PDF: Many applications and operating systems have a "Print to PDF" option that allows you to save a document as a PDF file instead of printing it on paper. Online converters: There are various online tools that can convert different file types to PDF. **How do I edit a Funai F42pdme Manual PDF?** Editing a PDF can be done with software like Adobe Acrobat, which allows direct editing of text, images, and other elements within the PDF. Some free tools, like PDFescape or Smallpdf, also offer basic editing capabilities. **How do I convert a Funai F42pdme Manual PDF to another file format?** There are multiple ways to convert a PDF to another format: Use online converters like Smallpdf, Zamzar, or Adobe Acrobats export feature to convert PDFs to formats like Word, Excel, JPEG, etc. Software like Adobe Acrobat, Microsoft Word, or other PDF editors may have options to export or save PDFs in different formats. **How do I password-protect a Funai F42pdme Manual PDF?** Most PDF editing software allows you to add password protection. In Adobe Acrobat, for instance, you can go to "File" -> "Properties" -> "Security" to set a password to restrict access or editing capabilities. Are there any free alternatives to Adobe Acrobat for working with PDFs? Yes, there are many free alternatives for working with PDFs, such as: LibreOffice: Offers PDF editing features. PDFsam: Allows splitting, merging, and editing PDFs. Foxit Reader: Provides basic PDF viewing and editing capabilities. How do I compress a PDF file? You can use online tools like Smallpdf, ILovePDF, or desktop software like Adobe Acrobat to compress PDF files without significant quality loss. Compression reduces the file size, making it easier to share and download. Can I fill out forms in a PDF file? Yes, most PDF viewers/editors like Adobe Acrobat, Preview (on Mac), or various online tools allow you to fill out forms in PDF files by selecting text fields and entering information. Are there any restrictions when working with PDFs? Some PDFs might have restrictions set by their creator, such as password protection, editing restrictions, or print restrictions. Breaking these restrictions might require specific software or tools, which may or may not be legal depending on the circumstances and local laws.

### **Find Funai F42pdme Manual :**

**fenwalnet 2015 manual**

**fiat dobro multijet service manual**

**fender fuse manual espanol**

**ferskes dyt beppe foar uacutes sjongt**

[fiat cinquecento 1991 1998 workshop repair service manual in italian 10102 quality](#)

[ferdydurke witold gombrowicz lecture duniversalis ebook](#)

*ferrari f430 spider workshop service repair manual*

**fete morts 2016 tradition mexicaine**

[fiat 411r operator manual](#)

[ferguson tef20 workshop manual](#)

[ferropolis wandkalender industriearchitektur eindrucksvoll monatskalender](#)

[fessenden presidents message delivered december](#)

**ferro five charger manual**

[fiat 500e service manual](#)

[fender super amp manual](#)

### **Funai F42pdme Manual :**

[ebook legacy and the queen the wizenard series 01](#) - Mar 06 2023

web legacy and the queen the wizenard series 01 legacy and the queen oct 16 2022 from the mind of basketball legend and academy award winning storyteller kobe bryant comes a new tale of finding your inner magic against all odds game set magic game tennis means life and death for the residents of the magical

[legacy and the queen the wizenard series 01 m p](#) - May 08 2023

web download and install the legacy and the queen the wizenard series 01 it is entirely easy then past currently we extend the associate to purchase and make bargains to download and install legacy and the queen the wizenard series 01 appropriately simple legacy and the double kobe bryant 2021 08 24

**legacyandthequeenthewizenardseries01 git livnsense** - Jan 24 2022

web follow up to the 1 new york times bestseller legacy and the queen legacy petrin is a national tennis champion but she doesn't feel like one at the orphanage where she grew up far from the city where she learned to shine legacy struggles to focus on her training her famous magical inner light dims and darkens until she barely recognizes

**legacy and the queen the wizenard series 01** - Mar 26 2022

web 2 legacy and the queen the wizenard series 01 2019 05 26 carissa darnell lost almost everything in the conquest left the sole heir and rightful queen of basium following the slaughter of her family she hungers for vengeance against the warmonger who took it all from her a puppet monarch she hides a dark and dangerous magic

[the wizenard series training camp the wizenard series 1](#) - Sep 12 2023

web audible sample follow the author kobe bryant the wizenard series training camp the wizenard series 1 hardcover march 19 2019 by wesley king author kobe bryant creator

**legacy and the queen the wizenard series 01 pdf** - Aug 31 2022

web legacy and the queen the wizenard series 01 recognizing the mannerism ways to get this book legacy and the queen the



wizenard series 01 is additionally useful you have remained in right site to begin getting this info acquire the legacy and the queen the wizenard series 01 belong to that we provide here and check out the link

*legacy and the queen the wizenard series 01 john flanagan* - Jun 09 2023

web legacy and the double kobe bryant 2021 08 24 kobe bryant s legacy of uplifting and inspiring young athletes continues in this highly anticipated follow up to the 1 new york times bestseller legacy and the queen legacy petrin is a national tennis champion but she doesn t feel like one at the orphanage

legacy and the queen the wizenard series 01 2022 - Feb 22 2022

web we meet the expense of legacy and the queen the wizenard series 01 and numerous book collections from fictions to scientific research in any way in the midst of them is this legacy and the queen the wizenard series 01 that can be your partner legacy and the queen the wizenard series 01 downloaded from registration joniandfriends org by

legacy and the queen hardcover illustrated sept 3 2019 - Dec 03 2022

web this story of a young heroine who must find friends at a specialized school so that she can prove herself to her privileged critics has plenty of charm and legacy is a protagonist worth cheering for publisher s weekly an ambitious crossover between fantasy dystopian and sports fiction a tennis themed mash up of suzanne

*granity studios books* - Jan 04 2023

web the wizenard series season one 1 new york times bestseller reggie has never felt destined for greatness he dreams about basketball brilliance all day and night but the hard truth is that he s a benchwarmer for the west bottom badgers the worst team in the league

*legacy and the queen the wizenard series 01 2022* - Aug 11 2023

web legacy and the queen the wizenard series 01 3 3 to her kyle is determined to break through melanie s walls but when she makes it clear she doesn t talk about her past he doesn t push he struggles to give her space even

**legacy and the queen the wizenard series 01 kwame** - Jul 10 2023

web the middle of guides you could enjoy now is legacy and the queen the wizenard series 01 below tiger moth insect ninja aaron reynolds 2006 08 27 young tiger moth is a ninja in training a martial arts warrior who fights evil in the streets and classrooms of the bug world with the help of his best friend pillbug kung pow he works for

**legacy and the queen the wizenard series 01 2022** - Feb 05 2023

web as this legacy and the queen the wizenard series 01 it ends happening living thing one of the favored ebook legacy and the queen the wizenard series 01 collections that we have this is why you remain in the best website to look the unbelievable book to have legacy and the queen the wizenard series 01 downloaded from

*legacy and the queen the wizenard series 01 pdf download* - Apr 07 2023

web legacy and the queen the wizenard series 01 pdf legacy and the queen the wizenard series 01 pdf book review unveiling the magic of language in an electronic era where connections and knowledge reign supreme the enchanting power of language has are more apparent than ever

[legacy and the queen legacy and the queen series 1](#) - Apr 26 2022

web sep 3 2019 overview 1 new york times bestseller from the mind of basketball legend and academy award winning storyteller kobe bryant comes a new tale of finding your inner magic against all odds game set magic

**legacy and the queen the wizenard series 01** - Nov 02 2022

web henry viii s legacy to elizabeth is illegitimacy religious strife and an elder sister determined to eliminate her queen only through the suspect offices of shifty court intriguers and her own risky political flair elizabeth denies her true feelings all her ruling life the wizenard series season one hachette uk no one has ever heard of a

[legacy and the queen the wizenard series 01 copy](#) - May 28 2022

web this legacy and the queen the wizenard series 01 can be taken as without difficulty as picked to act legacy and the queen the wizenard series 01 downloaded from nc tmuniverse com by guest frey evelin robert owen and his legacy simon and schuster journalist suffragist antilynching crusader in 1862 ida b wells was born

**legacy and the queen the wizenard series 01 api 2 crabplace** - Jun 28 2022

web legacy and the queen the wizenard series 01 1 legacy and the queen the wizenard series 01 geese are never swans forever terry queen s surrender the wayward prince the queen s true worth unravelling the public private finances of queen elizabeth ii the wizenard series season one home court children of blood

**legacy and the queen the wizenard series 01** - Jul 30 2022

web the wizenard series season one little brown the riveting history of a beautiful queen a shocking murder a papal trial and a reign as triumphant as any in the middle ages

[legacy and the queen the wizenard series 01 aaron](#) - Oct 01 2022

web merely said the legacy and the queen the wizenard series 01 is universally compatible like any devices to read fence sarah rees brennan 2020 the boys of kings row are assigned a course of team building exercises to deepen their bonds it takes a shoplifting scandal a couple of moonlit

**diakonie biblische Grundlagen und Orientierungen ein** - May 20 2023

web die Erinnerung an biblische Begründungszusammenhänge und Orientierungen will der notwendigen Verständigung über Grund und Zielperspektiven der Diakonie dienen damit leistet davorliegende Band einen Beitrag zur theologischen Überprüfung des gegenwärtigenselbstverständnisses der Diakonie

*diakonie meinunterricht* - Oct 13 2022

web arbeitsblätter für religion und ethik diakonie meinunterricht ist ein fächerübergreifendes online portal für lehrkräfte auf dem du hochwertiges unterrichtsmaterial ganz einfach herunterladen und ohne rechtliche bedenken für deinen unterricht verwenden kannst indem ich mich registriere stimme ich den agb und den

[pdf diakonie in biblischer orientierung free download pdf](#) - Jul 10 2022

web mar 1 2018 a neutestamentliche analysen zur diakonie das folgende kapitel befasst sich im ersten teil eingehend mit der bedeutung des wortes diakonie und seiner varianten im neuen testament 1 der zweite teil geht dann auf wesentliche andere biblische grundlagen für diakonisches handeln ein 2 1

*diakonie biblische grundlagen und orientierungen* - Mar 06 2022

web 2 diakonie biblische grundlagen und orientierungen 2023 07 08 diakonie inszenieren bod books on demand der band diakonik bietet eine solide einföhrung in die biblisch theologischen grundlagen sowie gegenwärtigen diskurse im bereich der diakonie

**neutestamentliche grundlagen diakonischen handelns brill** - Feb 17 2023

web 3 vgl folgende überblicke zu diakonie im neuen testament schäfer gerhard k storm theodor hg diakonie biblische grundlagen und orientierungen ein arbeitsbuch veröffentlichungen dwi heidelberg 2 heidelberg 31989 collins john n diakonia re interpreting the ancient sources

**diakonie biblische grundlagen und orientierungen** - Jan 04 2022

web diakonie biblische grundlagen und orientierungen protestantische schulkulturen puzzling the parables of jesus innere mission volksmission diakoniewissenschaft 4 diakonie biblische grundlagen und orientierungen 2021 03 23 chr grethlein e hauschildt j hermelink i karle r kunz m laube m meyer blanck u pohl

[caritas diakonie bibelwissenschaft](#) - Jan 16 2023

web diakonisches und caritatives handeln auf der grundlage der biblischen tradition speist sich aus denselben quellen der begriff diakonie verweist auf die pragmatische handlungsstruktur des dienens der begriff caritas auf die erkenntnisleitende intentionale motivationsstruktur einer messianischen praxis

**diakonie biblische grundlagen und orientierungen winter verlag** - Aug 23 2023

web 19 00 in den warenkorb legen 3 auflage 1998 3 auflage 425 seiten isbn 978 3 8253 7094 7 sortiment buch ausgabe kartoniert reihe veröffentlichungen des diakoniewissenschaftlichen instituts an der universität heidelberg band 2 lieferbar 15 01 1998 schlagwörter diakonie

**was ist diakonie biblische fundamente und christliche** - Apr 19 2023

web zur diakonie gehört also nicht nur die unmittelbare hilfeleistung und verkleinerung oder abwendung des leidens sondern zugleich die suche nach den leidenschaftenden politischen und strukturellen herkünften und die daraus resultierende

sozialpolitische und wirtschaftspolitische position

*diakonie biblische grundlagen und orientierungen fileshare* - Apr 07 2022

web diakonie biblische grundlagen und orientierungen gemeindediakonie pastoral epistles volume 46 diakonat und kirchenreform the parables of jesus theologie der helfenden berufe spiritual needs in research and practice gemeinde Ämter dienste diakonie und verkündigung puzzling the parables of jesus deacons and the church

**diakonie biblische grundlagen und orientierungen open library** - Jun 21 2023

web jan 1 1998 imported from amazon com record diakonie biblische grundlagen und orientierungen by gerhard k schäfer theodor strohm january 1 1998 universitätsverlag winter edition paperback

**diakonie biblische grundlagen und orientierungen copy** - Aug 11 2022

web diakonie biblische grundlagen und orientierungen 1 diakonie biblische grundlagen und orientierungen diakonische kirche diakonie und verkündigung innere mission volksmission diakoniewissenschaft diakonie eine einföhrung an exegetical bibliography of the new testament romans and galatians diakonat und kirchenreform

*diakonie biblische grundlagen und orientierungen ein a* - May 08 2022

web diakonie biblische grundlagen und orientierungen ein a buch zustand gut eur 3 49 zu verkaufen diakonie biblische grundlagen und orientierungen ein arbeitsbuch zur theologischen verständigung ü 385030700765

*diakonie in biblischer orientierung pdf kostenfreier download* - Mar 18 2023

web 1 diakonie in biblischer orientierung biblische grundlagen ethische konkretionen diakonisches leitungshandeln bearbeitet von prof dr dierk starnitzke 1 auflage taschenbuch 240 s paperback isbn format b x l 15 5 x 23 2 cm gewicht 365 g weitere fachgebiete religion christentum christliche theologie diakonie

*diakonie biblische grundlagen und orientierungen winter verlag* - Jul 22 2023

web die erinnerung an biblische begründungszusammenhänge und orientierungen will der notwendigen verständigung über grund und zielperspektiven der diakonie dienen damit leistet der vorliegende band einen beitrag zur theologischen Überprüfung des gegenwärtigen selbstverständnisses der diakonie

diakonie biblische grundlagen und orientierungen - Feb 05 2022

web diakonie biblische grundlagen und orientierungen diakonie in der sozialökonomie theologie der helfenden berufe jesus movement diakonia studies preaching on social suffering 4 diakonie biblische grundlagen und orientierungen 2022 09 07 orientierunge n vermitteln das heute notwendige wissen über die diakonie als eines

diakonik grundlagen konzeptionen diskurse google books - Nov 14 2022

web sep 12 2016 diakonik grundlagen konzeptionen diskurse johannes eurich heinz schmidt vandenhoek ruprecht sep 12 2016 religion 428 pages der band diakonik bietet eine solide einföhrung in die

*diakonie wikipedia* - Dec 15 2022

web unter diakonie altgriechisch διακονία diakonía dienst vgl auch διάκονος diákonos diener versteht man alle aspekte des dienstes am menschen im kirchlichen rahmen als eigener begriff für die wahrnehmung sozialer verantwortung durch die evangelischen kirchen im rahmen institutionalisierter eigener sozialer

*diakonie biblische grundlagen ab 7 80 diebuchsuche de* - Sep 12 2022

web diakonie biblische grundlagen und orientierungen ein arbeitsbuch zur theologischen verständigung den diakonischen auftrag veröffentlichungen instituts an der universität heidelberg 1998 search

**diakonie biblische grundlagen und orientierungen** - Jun 09 2022

web diakonie biblische grundlagen und orientierungen 3 3 die sich an pluralen orten in gemeinden und kirchenbezirke n in diakonischen projekten und sozialunterne hmen vernetzt im gemeinwesen gesellschaftlic h engagiert theorien von funktional ausdifferenzie rten kirchlichen strukturen und multiprofessio nellen teams werden

*to download the enrolment form please mrche pdf ftp popcake* - May 12 2023

web to download the enrolment form please mrche downloaded from ftp popcake com by guest alice alex handbook on the european convention on human rights m k update ltd written by an international team of ophthalmic practitioners this

**to download the enrolment form please mrche pdf** - Apr 30 2022

web title to download the enrolment form please mrche pdf pdf created date 6 14 2023 9 56 11 pm

**required documents for enrolment İstanbul** - Dec 27 2021

web written exam for knowledge of general musical culture 18 july 2017 at 10 00 o clock ethno musicology and folklore musical sensing exam 20 july 2017 at 10 00 o clock turkish composition written exam 21 july 2017 at 10 00 o clock interview 21 july 2017 at 13 00 o clock not to be older than age of twenty five 25 for opera program at the date

to download the enrolment form please mrche pdf - Jan 08 2023

web 4 to download the enrolment form please mrche 2020 12 30 other educational establishment s such as nurseries colleges special schools and pupil referral units covering grants crowdfunding event planning recycling schemes corporate support and much more this indispensable guide throws schools a lifeline by revealing the abundance of

**to download the enrolment form please mrche pdf 2023** - Apr 11 2023

web discover the declaration to download the enrolment form please mrche pdf that you are looking for it will no question squander the time however below taking into

to download the enrolment form please mrche full pdf - Mar 10 2023

web 2 to download the enrolment form please mrche 2023 05 10 expensive analysis is the impact that application form factor and scale has shown this astounding application form factor and scale self assessment will make you the assured application

form factor and scale domain adviser by revealing just what you need to know to be

**to download the enrolment form please mrche retailer bonide** - Nov 06 2022

web 2 to download the enrolment form please mrche 2022 12 13 news announcements printed material qr codes and much more don t flounder you don t have time get this book and win at web marketing employment news this week 8th mar to 15th march 2021 infobase publishing

entrance form to turkey register health gov tr turkey - Mar 30 2022

web passengers on flights to turkey will have to fill out a special electronic form also called entrance form to turkey however this rule does not apply to transit flights update in july 2023 entrance form to turkey is no longer required and the ministry of health website register health gov tr is no longer working

**to download the enrolment form please mrche pdf** - Oct 05 2022

web apr 21 2023 to download the enrolment form please mrche 1 1 downloaded from uniport edu ng on april 21 2023 by guest to download the enrolment form please mrche if you ally dependence such a referred to download the enrolment form please mrche book that will find the money for you worth get the very best seller from us

**to download the enrolment form please mrche sql1 viewber co** - Feb 09 2023

web to download the enrolment form please mrche downloaded from sql1 viewber co uk by guest frey may daily graphic elsevier health sciences special edition of the federal register containing a codification of documents of general applicability and future effect as of april 1 with ancillaries code of federal regulations maronko moise

*to download the enrolment form please mrche pdf pdf* - Jun 13 2023

web webto download the enrolment form please mrche is available in our book collection an online access to it is set as public so you can download it instantly our book servers concapps nl srv1 concapps nl oezzsu to download the webto download the enrolment form please mrche enrolment form

**form a pre enrollment application form for non** - Jul 02 2022

web the candidate applies for pre enrolment in please cross out the options which do not apply as far as further documents to be attached to the present form are concerned the candidates must follow the instructions of the university that will examine the present application title microsoft word form a docx

*application and registration process bau bahçeşehir* - Jan 28 2022

web the student candidates to apply our programs firstly need to start formal application procedures by filling up online application form our candidates can only apply to three departments online application form is given access to the candidates in application periods stated in academic calendar

**to download the enrolment form please mrche** - Jun 01 2022

web jun 3 2023 you could rapidly fetch this to download the enrolment form please mrche after acquiring offer this to download the enrolment form please mrche as one of the greater part functioning sellers here will totally be paired with by the best possibilities to review along with guides you could enjoy now is to download the

to download the enrolment form please mrche - Aug 03 2022

web jun 4 2023 this to download the enrolment form please mrche as one of the majority running sellers here will completely be paired with by the best alternatives to review

2020 2021 enrollment guide within the framework - Aug 15 2023

web students enrollment will be deleted if they don t can t submit the required documents until 15 december 2020 enrollment can be carried out by the official power of attorney written procuration in cases where the enrollment is not possible in person the power of attorney must be translated into turkish and

**to download the enrolment form please mrche shopify ubp** - Sep 04 2022

web you could purchase lead to download the enrolment form please mrche or get it as soon as feasible you could speedily download this to download the enrolment form please mrche after getting deal so taking into consideration you require the books swiftly you can straight get it

**to download the enrolment form please mrche pdf pdf** - Jul 14 2023

web to download the enrolment form please mrche pdf pages 2 7 to download the enrolment form please mrche pdf upload caliva n williamson 2 7 downloaded from db chubstr com on september 1 2023 by caliva n williamson

**to download the enrolment form please mrche** - Dec 07 2022

web you could purchase guide to download the enrolment form please mrche or acquire it as soon as feasible you could speedily download this to download the enrolment form please mrche after getting deal

**how to fill entrance form to turkey register health gov tr** - Feb 26 2022

web mar 21 2021 register health gov tr turkish republic authorities announced new entrance form regulations for tourists starting from 15 march 2021 passengers on flights